

Anomalous Scaling at the Quantum Critical Point in Itinerant Antiferromagnets

Ar. Abanov

Los Alamos National Laboratory, Theoretical division, MS B262, Los Alamos, New Mexico 87545, USA

A. Chubukov*

Department of Physics, University of Wisconsin, Madison, Wisconsin 53706, USA

(Received 22 September 2004; published 14 December 2004)

We show that the Hertz ϕ^4 theory of quantum criticality is incomplete as it misses anomalous nonlocal contributions to the interaction vertices. For antiferromagnetic quantum transitions, we found that the theory is renormalizable only if the dynamical exponent $z = 2$. The upper critical dimension is still $d = 4 - z = 2$; however, the number of marginal vertices at $d = 2$ is infinite. As a result, the theory has a finite anomalous exponent already at the upper critical dimension. We show that for $d < 2$ the Gaussian fixed point splits into two non-Gaussian fixed points. For both fixed points, the dynamical exponent remains $z = 2$.

DOI: 10.1103/PhysRevLett.93.255702

PACS numbers: 64.60.-i, 05.50.+q, 75.10.Jm

Quantum phase transitions (QPT) at zero temperature are currently the subject of intensive experimental and theoretical study. These transitions occur in a number of itinerant fermionic systems under the change of pressure, doping, magnetic field, or some other external parameter. QPT are very different from finite temperature phase transitions, as the dynamics of the order parameter field can be neglected at finite T but cannot be neglected at $T = 0$. The conventional phase diagram in the (x, T) plane, where x is the external parameter, has three distinctive areas (see Fig. 1). The ordered phase (for most cases, antiferromagnetic) is to the left of the quantum critical point (QCP), the disordered, paramagnetic Fermi liquid phase is to the right, and right above the QCP there is a quantum critical regime that we will study. The system properties in this regime are governed by the quantum dynamics of slow fluctuations of the order parameter [1].

In his original approach to quantum criticality for itinerant fermions, Hertz [2] considered the coupling between fermions and the low-energy bosonic field which condenses at the QCP. He integrated out fast fermions and obtained an effective theory for the slow bosonic degrees of freedom, which, he argued, is the Landau-Ginsburg-Wilson (LGW) ϕ^4 theory with the upper critical dimension $d_{cr} = 4 - z$, where z is the dynamical exponent. At $d = d_{cr}$ the ϕ^4 vertex is marginal, above d_{cr} it is irrelevant, and for $d < d_{cr}$ it is relevant. Higher order ϕ^6 , etc., vertices are all irrelevant near d_{cr} . This theory was later extended by Millis [3] and others [4] to explain the finite temperature properties of metals in the vicinity of the QCP.

In recent years, the applicability of Hertz-Millis theory to quantum phase transitions in heavy fermion metals has been questioned. The theory seems to work in some systems but not in others (see, e.g., [5]). It has been suggested that this inconsistency may be due to the fact that QPT in some heavy fermion materials require two-band description and may be accompanied by the discon-

tinuous change of the area of the Fermi surface [6]. This phenomenon is not included in Hertz theory, which describes one-band itinerant models.

In this Letter, we consider QPT for which one-band description is valid, and the Fermi surface changes continuously through the transition. We show that even for these transitions Hertz's theory is incomplete. Specifically, we argue that upon integrating out fermions, the effective bosonic theory becomes nonlocal. We show that only the theory with $z = 2$ is renormalizable. For $d > d_{cr} = 2$ all interaction terms are irrelevant, and the fixed point is just Gaussian. However, for $z = 2$ and $d = 2$, *there is an infinite number of marginal terms in the effective action*. For $d < 2$, the Gaussian fixed point splits into two new fixed points, one stable and one unstable. The scaling dimensions for different components of the momentum are different for these new fixed points, and for both of them the dynamical exponent z measured in units of the most relevant component of the momentum equals 2.

The existence of an infinite number of marginal terms at $d = 2$ is in variance with the LGW theory, in which

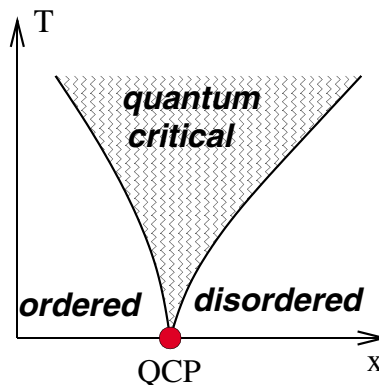

FIG. 1 (color online). The schematic phase diagram for quantum phase transition.

only ϕ^4 vertex is marginal. A single marginal vertex gives rise to only logarithmic corrections to a Gaussian theory and does not change critical exponents. This allows one to expand critical exponents in $\epsilon = 2 - d$. An infinite number of marginal vertices, however, gives rise to much stronger power law corrections, in which case ϵ expansion does not work, and anomalous exponents emerge already at the upper critical dimension. This, in particular, explains why explicit computations of the dynamical spin susceptibility [7] at the antiferromagnetic QCP in $d = 2$ yield $\chi(\Omega, \mathbf{q}) \propto ((\mathbf{Q} - \mathbf{q})^2 + |\Omega_m|)^{-1+\gamma}$ with the anomalous exponent $\gamma \approx 0.25$.

Our point of departure is the same as in Hertz theory—we consider fermions coupled to a bosonic field ϕ whose dynamics is governed by the dynamical exponent z . The Lagrangian density of this model has a form

$$L = \bar{c}_{\omega, \mathbf{k}} G_0^{-1}(\omega, \mathbf{k}) c_{\omega, \mathbf{k}} + \frac{1}{2} \chi_0^{-1}(\Omega, \mathbf{q}) \phi_{\Omega, \mathbf{q}}^2 + g \bar{c}_{\omega, \mathbf{k}} c_{\omega - \Omega, \mathbf{k} - \mathbf{q}} \phi_{\Omega, \mathbf{q}}, \quad (1)$$

where $\bar{c}_{\omega, \mathbf{k}}$ and $c_{\omega, \mathbf{k}}$ are Grassmann variables, g is the coupling constant, and the bare fermionic and bosonic propagators are

$$G_0^{-1}(\omega, \mathbf{k}) = \omega - \epsilon_{\mathbf{k}}, \quad (2)$$

$$\chi_0^{-1}(\Omega, \mathbf{q}) = \xi^{-2} + (\mathbf{q} - \mathbf{Q})^2 + (i\Omega)^{2/z}. \quad (3)$$

Here $\epsilon_{\mathbf{k}}$ is the quasiparticle excitation energy, ξ is the correlation length which diverges at the QCP, and \mathbf{Q} is the ordering vector for ϕ . An input for the theory is the assumption that there exist special hot spots (or lines) at the Fermi surface separated by \mathbf{Q} . In the absence of nesting, the Fermi velocities at \mathbf{k}_{hs} and $\mathbf{k}_{\text{hs}} + \mathbf{Q}$ are not antiparallel.

The action of Eq. (1) is quadratic in fermions and Hertz proceeded by integrating fermions out. This renormalizes $\chi_0(\Omega, \mathbf{q})$ and also introduces the interaction between bosonic fields: ϕ^4 , ϕ^6 terms, etc. Because of particle-hole symmetry, only terms with an even number of bosonic field are generated. The resulting action is [8]

$$S_H = \frac{1}{2} \int d\Omega d^2q \chi^{-1}(\Omega, \mathbf{q}) \phi_{\Omega, \mathbf{q}}^2 + \sum_{n=2}^{\infty} \int (d\Omega d^2q)^{2n-1} b_{2n} (\phi_{\Omega, \mathbf{q}})^{2n}. \quad (4)$$

The renormalization of $\chi(\Omega, \mathbf{q})$ and the vertices b_{2n} are given by the diagrams shown in Fig. 2. Hertz assumption that the vertices are local implies that they all can be evaluated at bosonic frequencies equal to zero and momenta equal to \mathbf{Q} . Consider b_4 as an example. The corresponding diagram contains two pairs of Green's functions with momenta near \mathbf{k}_{hs} and $\mathbf{k}_{\text{hs}} + \mathbf{Q}$ (see Fig. 2),

$$b_4 \sim \int \frac{d\omega d^2k}{(\omega - \epsilon_{\mathbf{k}} + i\delta_{\omega})^2} \frac{1}{(\omega - \epsilon_{\mathbf{k}+\mathbf{Q}} + i\delta_{\omega})^2}. \quad (5)$$

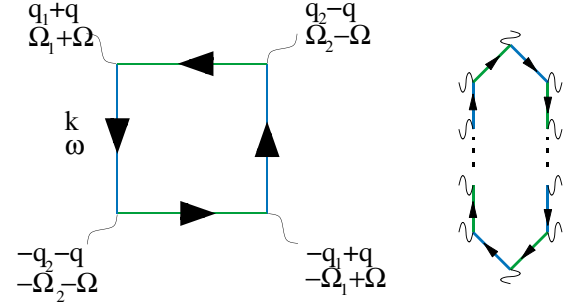

FIG. 2 (color). The diagram for the ϕ^4 term in the effective bosonic action (left) and the schematic diagram for ϕ^{2n} (right). Different colors show Green's functions near different hot spots.

One can easily make sure that once we linearize the dispersion near hot spots, the integral over momentum would vanish because of double poles [3]. This implies that the integral in (5) comes from electrons with high energies, of the order of bandwidth W , where the spectrum cannot be linearized. Accordingly, the value of b_4 scales inversely with W and vanishes in the continuum limit $W \rightarrow \infty$. The same consideration holds for all other b_{2n} . For finite W , all b_{2n} are just some constants. It is then straightforward to calculate the engineering dimensionalities of the couplings. Using the fact that $[\Omega] = z$ [see Eq. (3)], we immediately find that in $d = 2$ the dimensionality of the field is $[\phi_{\Omega, \mathbf{q}}^2] = -4 - z$, and the dimensionalities of the vertices are $[b_{2n}] = 2 - (n - 1)z$. For $z = 2$, this implies that b_4 is marginal, while all the other vertices are irrelevant. This is the known result of the Hertz theory [2,3].

We now demonstrate that the assumption of the locality of the interaction is, in fact, incorrect. Indeed, we found above that the integral in (5) is zero for a linearized dispersion because of double poles. However, this is true only when the bosonic frequencies Ω_i are zero. If we consider instead the limit $\Omega_i \rightarrow 0$, we find that there exists a tiny range of $|\omega| \leq |\Omega_i|$ where the double poles split into pairs of closely located poles in different half planes. The momentum integration then results in small denominators. This gives rise to universal, anomalous contributions to b_{2n} , which may be quite large if the small denominator overshoots the smallness of the frequency range.

Linearizing fermionic dispersion near \mathbf{k}_{hs} and $\mathbf{k}_{\text{hs}} + \mathbf{Q}$ and carrying out integration over momentum and frequency in Eq. (5) for nonzero bosonic frequencies Ω_i and $\mathbf{q}_i \neq \mathbf{Q}$, we find that

$$b_4 \propto \frac{g^4}{v_F^2} \frac{|\Omega|}{(\Omega - v_F \bar{q} + i\delta)^2}, \quad (6)$$

where $\bar{q} = q - Q$. The exact expression has a complex dependence on all external momenta and frequencies [7], but since we are only interested in the engineering dimensions, the estimate in (6) is sufficient. We see that b_4 strongly depends on the ratio $\Omega/v_F q$ and actually be-

comes large in the limit $\Omega \rightarrow 0$, $v_F q = 0$. We emphasize that b_4 in (6) is universal in the sense that it does not depend on the details of the fermionic dispersion at energies of order W and survives in the limit $W \rightarrow \infty$. Restricting with only universal piece in b_4 , we find that the ϕ^4 term in the effective bosonic action becomes

$$g_4 \int (d^2 q d\Omega)^3 \frac{|\Omega|}{(\Omega - v_F q + i\delta)^2} (\phi_{\Omega, \mathbf{q}})^4, \quad (7)$$

where $g_4 \sim g^4/v_F^2$. Performing the same calculation for vertices b_{2n} with $n > 2$, we obtain that

$$b_{2n} \propto \frac{g^{2n}}{v_F^2} \frac{|\Omega|}{(\Omega - v_F q + i\delta)^{2(n-1)}}. \quad (8)$$

Accordingly, the ϕ^{2n} term in the effective action takes the form

$$g_{2n} \int (d^2 q d\Omega)^{2n-1} \frac{|\Omega|}{(\Omega - v_F q + i\delta)^{2(n-1)}} (\phi_{\Omega, \mathbf{q}})^{2n}, \quad (9)$$

where $g_{2n} \propto g^{2n}/v_F^2$.

We can now reevaluate the scaling dimensionality of the vertices. Performing the same estimates as for the Hertz theory, we obtain

$$[g_{2n}] = (2 - z)n. \quad (10)$$

There are two consequences of this result. First, Eq. (10) holds for all n , down to $n = 1$. For $n = 1$, the universal g_2 vertex generated by fermions is

$$g_2 \int (d^2 q d\Omega) |\Omega| (\phi_{\Omega, \mathbf{q}})^2. \quad (11)$$

This is nothing but the Landau damping term. Adding the g_2 vertex to the Gaussian part of the bosonic action, we find that $z = 2$ is special in that the form of $\chi_0(\Omega, \mathbf{q})$ is reproduced; i.e., the bosonic dynamics is self-generated. Furthermore, $z = 2$ dynamics will obviously dominate even if in the bare $\chi_0(\Omega, \mathbf{q})$ $z < 2$. Second, we see from (10) that for $z = 2$ all vertices are marginal in $d = 2$. This is very different from the Hertz theory, where only the ϕ^4 vertex was marginal. There, a single marginal vertex leads to only logarithmic corrections to $\chi_0(\Omega, \mathbf{q})$ and did not modify critical exponents which remain mean field in $d = 2$. However, when the number of marginal vertices is infinite, this argument does not work as each vertex now gives rise to logarithmic corrections to the susceptibility. The infinite series of logarithms coming from all b_{2n} sum up into a power-law correction to the susceptibility, such that, at $\xi = \infty$,

$$\chi^{-1}(\Omega, \mathbf{q}) \propto ((\mathbf{q} - \mathbf{Q})^2 + |\Omega|)^{1-\gamma}, \quad (12)$$

where $\gamma > 0$. This implies that the system develops an anomalous exponent γ already at the *upper critical dimension*. The exponent $\gamma \sim 0.25$ was earlier obtained in perturbative $1/N$ calculations [7] for Eq. (3). The present consideration provides an understanding of its origin.

We next consider $d \neq 2$. For Hertz theory, simple power counting gives $[\phi^2] = -2 - d - z$, and $[b_{2n}] = (2 - d - z)n + d + z$. This implies that

$$[b_4] = 4 - d - z. \quad (13)$$

For $z = 2$, the ϕ^4 term is irrelevant for $d > 2$, marginal for $d = 2$, and relevant for $d < 2$. All other vertices are irrelevant near $d = 2$. However, as for $d = 2$, this power counting is invalidated because there exist universal, non-analytic contributions to b_{2n} which overshoot regular pieces. The calculation of the anomalous pieces in b_{2n} for $d \neq 2$ is a bit more involved compared to the $d = 2$ case as in arbitrary dimension—there exist hot manifolds on the Fermi surface instead of hot spots (see Fig. 3). Still, in a single scattering event, an electron is scattered from one hot manifold to another. We therefore can again split the Green's functions in the integrals for the vertices into the two groups belonging to one of two manifolds, and in each manifold evaluate the anomalous contribution coming from momentum integration transverse to the Fermi surface. The integration over the remaining components of momentum gives the volume of the manifold. Performing this integration, and also integrating over frequency, we obtain

$$b_{2n} \propto \frac{|\Omega|}{(\Omega - v_F q + i\delta)^{2(n-1)}}. \quad (14)$$

The ϕ^{2n} term in the action then becomes

$$g_{2n} \int (d^d q d\Omega)^{2n-1} (\phi_{\Omega, \mathbf{q}})^{2n}. \quad (15)$$

Simple power counting now yields

$$[g_{2n}] = d - 2 - (d + z - 4)n. \quad (16)$$

We see that the Gaussian part $[g_2] = 2 - z$ is independent of d ; i.e., $z = 2$ dynamics is self-generated in any dimension. We also see that, for $z = 2$, $g_{2n} = -(n - 1)(d - 2)$. This implies that for $d > 2$ all vertices with $n > 1$ are irrelevant, for $d = 2$ they are all marginal, and for $d < 2$ they are all relevant. We see therefore that for $d < 2$ the number of relevant vertices is *infinite*. This is another discrepancy with the Hertz theory.

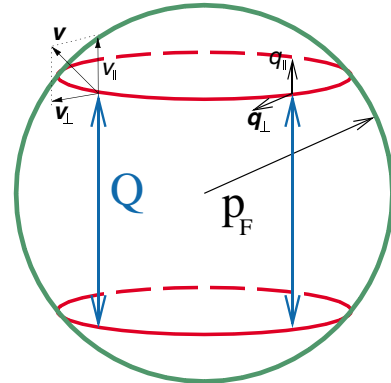

FIG. 3 (color). Hot manifolds in 3D.

The case $d < 2$ requires further study. Previous analysis of the scaling dimensions of the vertices pertained to a Gaussian fixed point. Below $d = 2$, this fixed point is no longer stable, and we need to find the new stable fixed point. Our strategy is the following: One can straightforwardly verify that for $d < 2$ the integration over the hot manifold, leading to Eq. (15), affects differently the components of the bosonic momenta parallel to the ordering momentum \mathbf{Q} and perpendicular to \mathbf{Q} (q_{\parallel} and \mathbf{q}_{\perp} , respectively). We therefore introduce an extra scaling dimensionality η for one of them. Using η as input, we obtain scaling dimensionalities of the coupling constants g_{2n} . We then use the fact that at the fixed point all vertices must be marginal and obtain the values of z and η at the new fixed points.

Let us measure the scaling dimensionalities in units of q_{\parallel} . Then, by definition, $[q_{\parallel}] = 1$, while for \mathbf{q}_{\perp} we introduce

$$[\mathbf{q}_{\perp}] = \eta. \quad (17)$$

The Gaussian part of the action is $\int (d^{d-1} q_{\perp} dq_{\parallel} d\Omega) \times (q_{\parallel}^2 + \mathbf{q}_{\perp}^2) \phi^2$. For $\eta > 1$ we can neglect \mathbf{q}_{\perp} in comparison to q_{\parallel} , while for $\eta < 1$ we can neglect q_{\parallel} in comparison to \mathbf{q}_{\perp} . Using this, we find after simple algebra that the dimensionality of the field is

$$\begin{aligned} [\phi^2] &= -3 - (d-1)\eta - z \quad \text{for } \eta > 1, \\ [\phi^2] &= -1 - (d+1)\eta - z \quad \text{for } \eta < 1. \end{aligned} \quad (18)$$

Using (18), we then find by straightforward calculations that the dimensionalities of the coupling constants g_{2n} are

$$\begin{aligned} [g_{2n}] &= n[3 - (d-1)\eta - z] + [(d-1)\eta - 1] \quad \text{for } \eta > 1, \\ [g_{2n}] &= n[-1 - (d-5)\eta - z] + [(d-3)\eta + 1] \quad \text{for } \eta < 1. \end{aligned} \quad (19)$$

(Care has to be taken in regularizing the infrared divergences in the momentum integrals for $\eta < 1$.) At the fixed point, $[g_{2n}] = 0$ for all n . Solving for $[g_{2n}] = 0$, we obtain

$$\left. \begin{aligned} \eta &= 1/(d-1) \\ z &= 2 \end{aligned} \right\} \quad \text{for } \eta > 1, \quad (20)$$

$$\left. \begin{aligned} \eta &= 1/(3-d) \\ z &= 2/(3-d) = 2\eta \end{aligned} \right\} \quad \text{for } \eta < 1. \quad (21)$$

We see from (20) and (21) that each inequality is indeed satisfied only if $d < 2$. This implies that for $d < 2$ there exist two fixed points. They progressively deviate from each other as $2 - d$ increases. Obviously, one of these fixed points is stable and the other is unstable. To determine which one is stable, we use the result of perturbative $1/N$ analysis of logarithmic corrections to $v_F q_{\parallel}$ and $v_F q_{\perp}$ for $d = 2$ [7]. According to Ref. [7], the ratio $q_{\perp}/q_{\parallel} \propto 1/\log \xi$ renormalizes to zero at $\xi = \infty$ (this makes the Fermi surface nested at the hot spots at the

QCP). By continuity, this implies that the stable fixed point is the one with $\eta > 1$. We see from (21) that at a stable non-Gaussian fixed point the dynamical exponent remains $z = 2$.

In summary we have demonstrated that Hertz theory of quantum criticality is incomplete. We have shown that all vertices in the effective bosonic theory possess universal, anomalous pieces which overshoot constant terms of the Hertz theory. For quadratic part of the action, this universal contribution is the Landau damping term. We found that $z = 2$ is special in that the theory is renormalizable for any d . The upper critical dimension for $z = 2$ is $d_{\text{cr}} = 2$, as in Hertz theory; however, the number of marginal vertices at $d = 2$ is infinite. This gives rise to the appearance of the anomalous exponent already at $d = 2$. For $d < 2$, the number of relevant vertices is infinite. We found that the Gaussian fixed point is unstable, and there exist two non-Gaussian fixed points with different scaling dimensions for different components of the momentum. At each of these new fixed points, there is an infinite number of marginal vertices. We found that one of these points is stable and one unstable. Still, for both fixed points, the dynamical exponent, measured in units of the largest component of the momentum, remains $z = 2$.

We acknowledge stimulating conversations with A. G. Abanov, I. Gruzberg, O. Starykh, and I. Vekhter. The work of Ar. A. was supported by the Oppenheimer Fellowship in Los Alamos. A. Ch. acknowledges support from NSF DMR 0240238. We thank the Aspen Center for Physics for hospitality.

*Present address: Department of Physics, University of Maryland, College Park, MD 20742, USA.

- [1] S. Sachdev, *Quantum Phase Transitions* (Cambridge University Press, Cambridge, 1999).
- [2] J. A. Hertz, Phys. Rev. B **14**, 1165 (1976).
- [3] A. J. Millis, Phys. Rev. B **48**, 7183 (1993).
- [4] T. Moriya and T. Takimoto, J. Phys. Soc. Jpn. **64**, 960 (1995).
- [5] P. Gegenwart, J. Custers, T. Tayama, K. Tenya, C. Geibel, G. Sparn, N. Harrison, P. Kersch, D. Eckert, K.-H. Müller, and F. Steglich, J. Low Temp. Phys. **133**, 3 (2003); J. Custers, P. Gegenwart, H. Wilhelm, K. Neumaier, Y. Tokiwa, O. Trovarelli, C. Geibel, F. Steglich, C. Pepin, and P. Coleman, Nature (London) **424**, 524 (2003).
- [6] P. Coleman, C. Pepin, Q. Si, and R. Ramazashvili, J. Phys. Condens. Matter **13**, 723 (2001); Q. Si *et al.*, Nature (London) **413**, 804 (2001).
- [7] Ar. Abanov, A. V. Chubukov, and J. Schmalian, Adv. Phys. **52**, 119 (2003).
- [8] Here and below we use symbolic notations. Each field ϕ actually depends on frequency and momentum. Also, the vertex b_2 accounts for the correction to the correlation length. We assume that this correction is already included in ξ^{-2} in Eq. (4).